



## Portable Helicopter FIRETRAINER<sup>®</sup> O-100

Fully Portable

Easy to Operate

Easy to Maintain

No Infrastructure Required

**KFT**<sup>™</sup>  
FIRE TRAINER

REALISTIC FIRE | HAZMAT | EMERGENCY TRAINING SOLUTIONS

[kft.firetrainer.com](http://kft.firetrainer.com)



passenger/cargo area fire



UH-60 Black Hawk and Huey models available



helicopter on trailer with propane tank storage

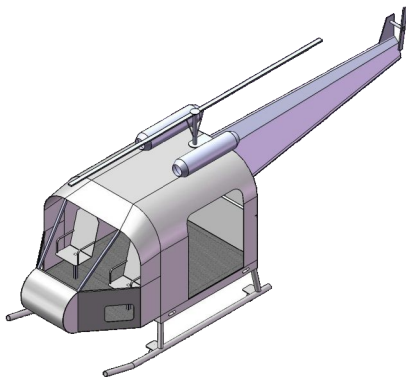

KFT's Portable Helicopter FIRETRAINER® O-100 is designed for training response personnel in helicopter fire emergencies. KFT's integral multi-zone burner design allows users to simulate numerous helicopter fire scenarios at the push of a button.

The Portable Helicopter FIRETRAINER® O-100 is extremely versatile with the ability to produce 63,000,000 btu/hr and scenarios such as:

- an engine fire
- a passenger/cargo area fire
- a cockpit fire

The heavy-duty steel frame and steel skin make the Portable Helicopter FIRETRAINER® extremely robust. Combining this with the stainless steel waterbath burner design provides unparalleled durability and ease of maintenance. The Portable Helicopter FIRETRAINER® burns environmentally acceptable propane. Safety is paramount with the ignition officer controlling a "deadman" button on the control pendant that when released instantly stops the fire. When paired with the optional self-contained transport trailer, training can be conducted almost anywhere.

KFT's FIRETRAINER® O-100 systems are certified to UL safety standards by Intertek (ETL), a Nationally Recognized Testing Laboratory (NRTL).



## Specifications

### Helicopter

- construction heavy-duty steel construction
- dimensions 24' Long x 7' Wide x 10' High
- features 2 cockpit seats, 2 engines (one operational for fire), cargo entry, main rotor and tail rotor rotate

### O-100

- construction stainless steel
- power 110VAC (50' AC power cable provided)
- features Water bath burner for increased realism, two-stage flame control, and hand-held operator pendant with 30' cable

### Custom Transportation Trailer

- dimensions 27' long x 8'6" wide, with a 24" deck height
- features two on-board propane tanks, on-board storage lockers for all O-100 equipment, winch with wireless remote for loading and unloading the helicopter

## Warranty & Support

- onsite startup and operator training
- 12-month parts warranty with toll-free support
- 24/7 toll-free technical phone support

 USA KFT Fire Trainer, LLC, 5 Pearl Court, Unit D, Allendale, NJ, 07401, USA  
+1.201.300.8100

 Germany KFT Fire Trainer GmbH, Sonnenweg 13, 52070 Aachen, Germany  
+49.241.180.580

 UK KFT Fire Trainer GmbH, Unit 1a Midland Place, Barlborough S43 4FR, UK  
+44.1246.819.755

 Hong Kong KFT APAC, Unit 1109, 11/F, Tower 3, Phase 1 Enterprise Square, 9 Sheung Yuet Road, Kowloon Bay, HK  
+852.3706.6333

[kft.firetrainer.com](http://kft.firetrainer.com)